

Tecator™ Digestion Systems



Tecator™ Digestion Unit Auto Lift 20 together with the Scrubber, for fully unattended operation.

Features and benefits:

Tecator™ Digestion units, with integrated programmable controllers, can be combined with a range of accessories offering:

- fully automated digestion with user interface adapting to actual product configuration
- convenient, safe and flexible operation
- GLP-support through two way PC communication
- economy of chemicals, energy, labour, space and time
- efficient fume containment through optional exhaust
- efficient fume removal through optional scrubber

The systems, with extensive application support, are compatible with Kjeltac™ Distilling Units.

General Description:

The products described in this brochure can be combined to match individual needs, from units capable of handling just a few samples a day up to fully automated systems for high sample throughput. Three configurations; Auto Lift, Auto Rack, and Basic; are available for either 250 ml or 100 ml digestion tubes; which must be specified when ordering; dependant on the application required.

A Digestion System is based on a Digestion Unit and tube rack with capacity for either eight or twenty tubes. For most Kjeldahl digestions straight 250 ml tubes are recommended. To comply with GLP and Health & Safety requirements we recommend that all Digestion Units are used with an Exhaust Manifold or Reflux Head, and are located in a fume cupboard. An optional Scrubber Unit creates a fully integrated system.

Auto Lift versions, with exhaust docking facility, allow fully automated unattended operation contributing to safety and convenience by eliminating handling of hot chemicals and saving valuable bench space. Auto Rack versions allow automated digestions but require manual placement of Tube Rack and Exhaust Manifold which are stored above the Digestion Unit in a similar position to the Auto Lift. All Auto models have an integrated programmer which precisely controls temperature(s) and timing together with connected components. The analysis cycle is clearly monitored on the graphical display. Auto models can be connected to a PC for data logging and downloading of standard, and user defined, applications. The programmer has various password protected access levels to prevent unauthorised modification and comply with accreditation procedures. Basic versions have built in, user definable, temperature and time control clearly viewed on the display.

Auto Rack versions can be upgraded to Auto Lift systems to spread the investment across fiscal periods.

The Basic version can be fitted with a rack system at any time to save valuable bench space.

Various accessories are available to make routine analysis safe and simple. They include a range of test tubes, tube racks, retainer plates for washing, fume removal systems, boiling rods and catalyst tablets.

Digestion system products and accessories are described in more detail on the following pages.



All Digestion Systems are based on one of the "four" Digestion Units for either 250 ml or 100 ml tubes*.
 * Tube volume to be specified when ordering your digestion unit.

Digestion Units

The Digestion Units are insulated to minimise heat transfer to the surroundings and allow fast, even heating, thus giving good working conditions as well as saving energy. They are designed for batches of either eight or twenty test tubes with three different levels of control.

The Auto versions have an integrated all activity controller, that adapts to the actual product configuration and is programmable using the software supplied. When a Lift or Scrubber Unit is connected they are controlled by the selected application program, which is stored in the Digestion Unit memory, allowing fully unattended operation.

The Basic versions have a built in, user definable, time and temperature controller and display.

Software for Auto Lift and Auto Rack systems

There are two separate software systems in Auto versions. The embedded software controls all necessary functions of the digestion system on a routine basis. The PC Application software, delivered on CD, is system management software which enables default values to be modified according to the needs of the authorised user. To process different type of samples a wide range of Tecator™ applications can be downloaded from the database included on the CD. Up to 254 Applications can be stored in the digestion unit at any one time, of which half can be standard Tecator™ format and half can be user defined. Each application can control up to 23 steps including all Temperature; ramp and time; Lift and Scrubber steps.

The software supports Good Laboratory Practice (GLP) routines and accreditation procedures. Data for date, time, temperature, application used, operator, batch number, and ID number are constantly logged. The 32 most recent Data Logs can be stored in the Digestion Unit. All this information can be transferred to a PC for archiving and generation of up to seven different reports. Original Tecator™ Applications cannot be changed. They can be adapted and saved as different files or the user can design their own applications. To prevent unauthorised changes, and comply with GLP routines, the software is password protected at different authority levels.

Audible alerts

Audible "ready" or "cycle over" alerts advise the user when the digestion application is completed

Audible "alarm" alerts advise the user when errors/interruptions occur within the running application program

Alerts can be adjusted High, Low or Off.

Power failure or interruption of power supply

In the event of power failure the digestion unit operation is automatically handled in the safest way. If the failure or interruption occurs at any time up to or during preheating, before digestion has started, the cycle will continue when power is restored. Following a power failure or interruption, after the digestion cycle has started, the unit stops heating immediately and the Lift goes to the cooling position with exhaust in place, upon restoration of power. This complies with GLP and Health & Safety routines. These interruptions will be recorded in the data logging function.

Communication with PC

The PC Application software has two way communication with the Digestion Unit via the serial RS232 cable supplied as standard. Alternatively communication can be achieved through Bluetooth TDK blu2i modules, or equivalent, available from your computer supplier.

Language versions

The software is available in the following languages:- Chinese (simplified), Dutch, English, French, German, Italian, Japanese, Korean, Polish, Russian, Spanish, and Swedish. Other languages can be accommodated in co-operation with your local supplier.

Auto Lift Systems

Auto Lift systems facilitate highly automated procedures, eliminating heavy and risky handling of hot chemicals. Valuable bench space is saved, as the Tube Rack and Exhaust Manifold are positioned above the Digestion Unit.

A Tube Rack with 8 or 20 tubes is placed in the Lift. The application selected then fully controls the entire process. The Exhaust Manifold docks automatically with the Tube Rack as they move down into the preheated Digestion Unit; and the Scrubber Unit, if connected, starts.

The scrubber capacity is automatically adjusted during the cycle to contain fumes and minimise acid losses. When the digestion is completed the combined Tube Rack and Exhaust Manifold move to the cooling position with the Scrubber Unit still running until no further fumes are evolved. An adjustable audible signal in the Digestion Unit indicates "cycle over".

To avoid any spillage a drip tray, supplied with the Exhaust Manifold, is inserted underneath the Exhaust Manifold when it is separated from the Tube Rack after cooling.



The Lift eliminates heavy handling.



The Rack System saves space.

Auto Rack Systems

When an Auto Rack system is used in place of an Auto Lift system the typical procedure is as with the Auto Lift system with the exception that the combining/separating of Tube Rack and Exhaust Manifold and the movement to the cooling position is performed manually when the signal is heard. The application selected controls all other functions as with the Auto Lift system.

Basic Systems

The temperature and time for the digestion are selected on the front panel. All other procedures, including operation of a connected scrubber, are then performed by the operator once the digestion unit has reached the selected temperature.

Fume Removal and Containment Systems Exhaust Manifolds

Many digestion applications, e.g. Kjeldahl, produce fumes that are unpleasant and corrosive. Exhaust Manifolds designed for each Digestion Unit facilitate fume removal and containment and are strongly recommended for use with all digestion procedures. The cost of replacement of a fume cupboard which has been corroded by inefficient fume handling is very much greater than the relatively low cost of an approved exhaust. Whilst many users choose to operate integrated systems in the open laboratory, we strongly recommend the use of both exhaust systems and fume cupboards for these operations. This is simply Good Laboratory Practice (GLP) and avoids conflict with local Health & Safety (H&S) requirements.

The Exhaust Manifolds should be connected to the water aspirator supplied, or to a suitable Scrubber Unit.

Scrubber Unit

Where water is a scarce or expensive commodity, or simply when a higher level of automation is desired, the water aspirator should be replaced with an efficient Scrubber Unit. Exhaust Manifolds and Scrubber Units which require an external water source are subject to variation in vacuum efficiency due to fluctuations in local water pressure.

The compact bench top Tecator™ Scrubber Unit is self contained and is therefore unaffected by water supply issues. During digestion moist, acidic fumes from the connected exhaust are drawn through the Scrubber Unit. Acid vapours are first condensed and diluted in a large acid trap. Any residual fumes are collected, washed and neutralised before passing through a second small acid trap which protects the vacuum pump in the event that the scrubbing agents are exhausted. The cleaned air is then

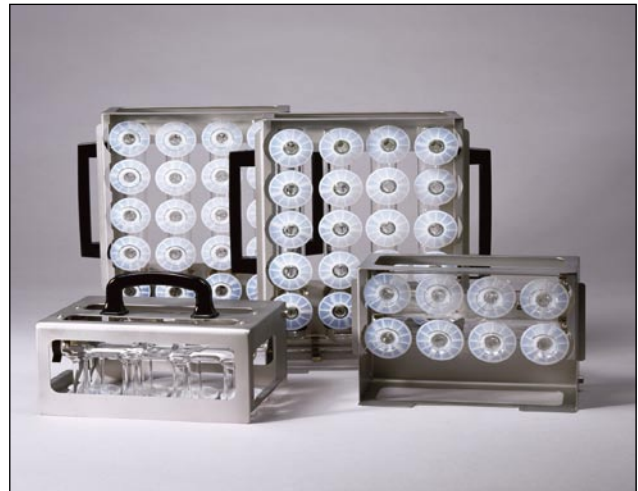

There is an Exhaust for each Digestion Unit.



The Scrubber neutralizes the corrosive fumes.



There are Reflux Heads for 250 ml Digestion Units.



Select the correct tube for your application.



Kjeltabs, salt and catalyst in tablet form.

vented via a tubing outlet. In the interest of GLP and H&S this venting tube should be directed into a fume cupboard. When the Scrubber Unit is connected to an Auto Lift or Auto Rack system the program will fully control the function including switching from high to low aspiration settings.

Reflux Heads

When a digestion unit is used for reflux chemistries, such as Chemical Oxygen Demand (COD), a Reflux Head connected to a suitable cold water supply should be used in place of the Exhaust Manifold. Tecator™ Reflux Heads are conveniently mounted in handling racks which match the tube rack in the Digestion Unit. The ball jointed condensers are designed for use with ball jointed digestion tubes. The Reflux Heads are compatible with Auto Lift, Auto Rack and Basic systems.

Digestion Tubes

To suit different applications and manual/automatic handling systems, tubes for the Digestion Units are available in two sizes (250 ml and 100 ml) and three shapes. Straight sided tubes are recommended for the majority of digestion applications. Volumetric tubes with a constriction at the neck are recommended for applications where the digestate requires dilution to a fixed volume before analyses such as FIA, SFA, and AA etc. Ball jointed tubes, available in 250 ml size only, are required for reflux chemistries using the reflux condenser heads. The larger 250 ml straight sided tubes are recommended for Kjeldahl, as they can hold samples of widely varying sizes. Samples of heterogeneous material often need to be fairly large to ensure that they are representative. There is no lower limit of sample size in the 250 ml tubes; they simply allow greater flexibility for most type of samples.

The 100 ml straight sided tubes can be used where the material is homogeneous and small samples are fully representative or where they are specified by the approved method.

Kjeltabs

A salt, to increase the boiling point, and a catalyst, to increase the speed of reaction, are used for Kjeldahl digestions. As a convenient way to obtain the correct dosage, FOSS supplies Kjeltabs – tablets containing Potassium Sulphate and a catalyst (Copper, Selenium, or Copper/Titanium). Digestion time may depend on the catalyst used. Historically Mercury has been used as the most efficient catalyst. Today it has been replaced largely by Copper, or other metals, due to safety and environmental considerations. Kjeltabs are supplied in two sizes; 3.5 g and 1.5 g. One or more tablets are combined with the acid to obtain an optimal salt/acid ratio. The smaller 1.5 g size is designed for the 100 ml tubes.

Ordering information:*

Digestion Units:

All models are delivered with a Tube Rack with integrated heat shields. They should always be combined with a matching Exhaust Manifold or Reflux Head and Test Tubes – 100 or 250 ml volume.

For Kjeldahl digestions the 2501-001 Scrubber Unit should always be considered for safe and efficient neutralisation of corrosive gases. This replaces the water aspirator, supplied as standard.

Auto Lift models, complete with 2515-001 Lift and integrated controller for fully automatic control of digestion applications, including the operation of the Lift and a 2501-001 Scrubber Unit (optional extra). The digestion unit can be connected to PC for application updates, traceability and logging purposes.

NOTE. An appropriate exhaust manifold or reflux head MUST be added for an automatic system.

Auto Rack models, complete with 2515-011 Rack and integrated controller for full control of digestion applications, including the operation of a 2501-001 Scrubber (optional extra). The digestion unit can be connected to PC for application updates, traceability and logging purposes.

Can be upgraded to an Auto Lift system by addition of the 2515-001 Lift.

NOTE. An appropriate exhaust manifold or reflux head MUST be added for an automatic system.

Basic models, with built in electronics for control of temperature and time only.

Can not be upgraded to Auto models but are compatible with 2515-011 Rack.

Tecator™ Auto Digestion Units

Auto models with integrated all activity controller and graphical display.

Versions for 250 ml tubes

- 2508-001 Tecator™ Digestion Unit 8 – Auto Lift system, 250 ml tubes, 230 V 50-60 Hz
- 2508-002 Same as above but for 110 V 50-60 Hz
- 2508-011 Tecator™ Digestion Unit 8 – Auto Rack system, 250 ml tubes, 230 V 50-60 Hz
- 2508-012 Same as above but for 110 V 50-60 Hz
- 2520-001 Tecator™ Digestion Unit 20 – Auto Lift system, 250 ml tubes, 230 V 50-60 Hz
- 2520-011 Tecator™ Digestion Unit 20 – Auto Rack system, 250 ml tubes, 230 V 50-60 Hz

Versions for 100 ml tubes

- 2508-006 Tecator™ Digestion Unit 8 – Auto Lift system, 100 ml tubes, 230 V 50-60 Hz
- 2508-007 Same as above but for 110 V 50-60 Hz
- 2508-016 Tecator™ Digestion Unit 8 – Auto Rack system, 100 ml tubes, 230 V 50-60 Hz
- 2508-017 Same as above but for 110 V 50-60 Hz
- 2520-006 Tecator™ Digestion Unit 20 – Auto Lift system, 100 ml tubes, 230 V 50-60 Hz
- 2520-016 Tecator™ Digestion Unit 20 – Auto Rack system, 100 ml tubes, 230 V 50-60 Hz

Tecator™ Digestion Units

Basic models with built in electronics for control of temperature and time.

Versions for 250 ml tubes

- 2508-051 Tecator™ Digestion Unit 8 – Basic, 250 ml tubes, 230 V 50-60 Hz
- 2508-052 Same as above but for 110 V 50-60 Hz
- 2520-051 Tecator™ Digestion Unit 20 – Basic 250 ml tubes, 230 V 50-60 Hz

Versions for 100 ml tubes

- 2508-056 Tecator™ Digestion Unit 8 – Basic, 100 ml tubes, 230 V 50-60 Hz
- 2508-057 Same as above but for 110 V 50-60 Hz
- 2520-056 Tecator™ Digestion Unit 20 – Basic 100 ml tubes, 230 V 50-60 Hz

Fume Removal & Containment Systems

- 2508-020 Exhaust Manifold for Digestion Units 2508, if 250 ml tubes are used.
Complete with Water Aspirator and Drip Tray.
- 2508-021 Exhaust Manifold for Digestion Units 2508, if 100 ml tubes are used.
Complete with Water Aspirator and Drip Tray.
- 2520-020 Exhaust Manifold for Digestion Units 2520, if 250 ml tubes are used.
Complete with Water Aspirator and Drip Tray.
- 2520-021 Exhaust Manifold for Digestion Units 2520, if 100 ml tubes are used.
Complete with Water Aspirator and Drip Tray.
- 2501-001 Scrubber Unit 110/230 V 50-60 Hz.
For neutralization of fumes in acid digestions. It can be combined with any of the Exhaust Manifolds. Up to 100 samples without changing of reagent. Fully automatic operation when connected to an Auto Digestion Unit.

Lift & Rack Systems

- 2515-001 LIFT for the AUTO version of Digestion Unit 2508 and 2520.
The Application run in the Digestion Unit fully controls the LIFT.
The Lift can only be connected to Auto version Digestion Unit.
- 2515-011 RACK System for all versions of Digestion Unit 2508 and 2520 without LIFT.
Enables manual positioning of components in a similar way as the Auto Lift.

Reflux condensers

- 2508-030 Reflux Head COD Digestion Unit 2508.
Water-cooled Condensers for 8x250 ml tubes.
- 2520-030 Reflux Head COD Digestion Unit 2520.
Water-cooled Condensers for 20x250 ml tubes.
- 10000254 Reflux Condenser, Air Cooled.
700 mm. With ground joint for 250 ml tubes.

Cont. Ordering information:*

Handling Systems

Digestion Units are delivered complete with one Tube Rack. It may be found convenient to order extra so that all tubes normally in use in the laboratory are placed in a rack.

All Tube Racks fit the Kjelttec 2460 Sampler.

- 10014245 Tube Rack for 8 Digestion Tubes 250 ml.
- 10014248 Tube Rack for 8 Digestion Tubes 100 ml.
- 10014240 Tube Rack for 20 Digestion Tubes 250 ml.
- 10014246 Tube Rack for 20 Digestion Tubes 100 ml.
- 10014006 Retainer Plate for Washing; Digestor 2520, 250 ml Tubes.
- 10014007 Retainer Plate for Washing; Digestor 2520, 100 ml Tubes.
- 10000460 Boiling Rod

To avoid bumping when digesting large volumes of water.

- 10000897 Handling Device for Digestion Tube
- 10007117 Dispenser 2-10 ml, 1000 ml Bottle
- 10007118 Dispenser 10-30 ml, 2000 ml Bottle

Test tubes

Straight model Test Tubes, often used for Kjeldahl determination.

- 10014311 Digestion Tubes Straight 100 ml 8/pkg
- 10014312 Digestion Tubes Straight 100 ml 20/pkg
- 10014278 Digestion Tubes Straight 250 ml 8/pkg
- 10000158 Digestion Tubes Straight 250 ml 20/pkg

With constriction and volume mark, used in applications where the digest is diluted to volume and an aliquot is taken for analysis.

- 10014313 Digestion Tubes With Mark 100 ml 8/pkg
- 10014314 Digestion Tubes With Mark 100 ml 20/pkg
- 10014315 Digestion Tubes With Mark 250 ml 8/pkg
- 10000157 Digestion Tubes With Mark 250 ml 20/pkg

With ground joint for air-cooled Reflux Condensers.

- 10014316 Digestion Tubes - Ground Joint 250 ml 8/pkg
- 10000159 Digestion Tubes - Ground Joint 250 ml 20/pkg

With ball joint for water-cooled Reflux Condensers.

- 10014317 Digestion Tubes - Ball Joint 250 ml 8/pkg
- 10000611 Digestion Tubes - Ball Joint 250 ml 20/pkg

Kjeltabs:

Most types are delivered in boxes of 1000.

- 15270001 Selenium, Tablets with 1.5 g K_2SO_4 + 7.5 mg Se.
- 15270002 Selenium, Tablets with 5 g K_2SO_4 + 5 mg Se.
- 15270003 Selenium, Tablets with 3.5 g K_2SO_4 + 3.5 mg Se.
- 15270056 Selenium, Tablets with 1 g Na_2SO_4 + 0.05 g Se.
- 15270010 Copper/Titanium, Tablets with 5 g K_2SO_4 + 0.15 g $CuSO_4 \cdot 5H_2O$ + 0.15 g TiO_2 .
- 15270020 Copper/Titanium, Tablets with 3.5 g K_2SO_4 + 0.105 g $CuSO_4 \cdot 5H_2O$ + 0.105 g TiO_2 .
- 15270018 Copper, Tablets with 3.5 g K_2SO_4 + 0.4 g $CuSO_4 \cdot 5H_2O$.
- 15270034 Copper, Tablets with 1.5 g K_2SO_4 + 0.15 g $CuSO_4 \cdot 5H_2O$.
- 15270057 Copper, Tablets with 4.5 g K_2SO_4 + 0.5 g $CuSO_4 \cdot 5H_2O$.

Other types are available upon request

Installation requirements:

Digestion Unit 2508 Auto

Power Supply:	200 - 240 V or 100 - 115 V, 50 - 60 Hz
Power consumption:	1100 W
Water supply:	See Exhaust Manifolds. If Scrubber connected - None
Weight:	10 kg
Dimensions, W × D × H:	300 × 500 × 697 mm (incl. Rack system)
Ambient temperature:	max 40°C
Ventilation requirement:	Exhaust system and Fume hood
Recommended bench space:	1 m, or 0.4 m if a Lift or Racking System is used

Digestion Unit 2508 Basic

Power Supply:	200 - 240 V or 100 - 115 V, 50 - 60 Hz
Power consumption:	1100 W
Water supply:	See Exhaust Manifolds. If Scrubber connected - None
Weight:	10 kg
Dimensions, W × D × H:	300 × 390 × 140 mm
Ambient temperature:	max 40°C
Ventilation requirement:	Exhaust system and Fume hood
Recommended bench space:	1 m, or 0.4 m if a Racking Sys- tem is used

Digestion Unit 2520 Auto

Power Supply:	200 - 240 V, 50 - 60 Hz
Power consumption:	2300 W
Water supply:	See Exhaust Manifolds. If Scrubber connected - None
Weight:	18 kg
Dimensions, W × D × H:	300 × 660 × 697 mm (incl. Rack system)
Ambient temperature:	max 40°C
Ventilation requirement:	Exhaust system and Fume hood
Recommended bench space:	1 m, or 0.4 m if a Lift or Rack System is used

Digestion Unit 2520 Basic

Power Supply:	200 - 240 V, 50 - 60 Hz
Power consumption:	2300 W
Water supply:	See Exhaust Manifolds. If Scrubber connected - None
Weight:	18 kg
Dimensions, W × D × H:	300 × 550 × 140 mm
Ambient temperature:	max 40°C
Ventilation requirement:	Exhaust system and Fume hood
Recommended bench space:	1 m, or 0.4 m if a Rack System is used

Scrubber

Power Supply:	100 to 240 V, 50 - 60 Hz, Self selecting
Power consumption:	50 W
Water supply:	No
Weight:	19 kg
Dimensions, W × D × H:	335 × 485 × 395 mm
Ambient temperature:	max 40°C
Ventilation requirement:	Outlet tubing preferably into sink in fume hood
Recommended bench space:	0.6 m

Exhaust 2508

Water supply:	3 - 5 l/min for 5 minutes, then 1 l/min
---------------	--

Exhaust 2520

Water supply:	10 - 12 l/min for 5 minutes, then 3 - 5 l/min
---------------	--

Lift

Power Supply:	None. Powered from the Diges- tion Unit Auto
Power consumption:	10 W
Weight:	7 kg
Dimensions, W × D × H:	300 × 550 × 697 mm (Mounted on Digestion Unit)
Ambient temperature:	max 40 C
Ventilation requirement:	No
Recommended bench space:	0 m. Lift is mounted on the Digestion Unit

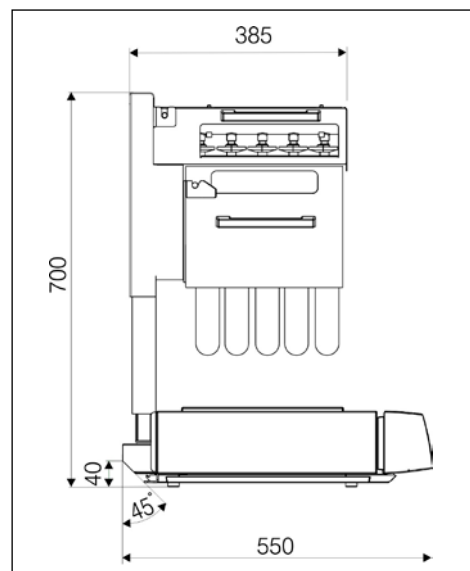

Performance data:				
	2508 Auto	2508 Basic	2520 Auto	2520 Basic
Temperature range	Ambient - 440°C	100 - 440°C	Ambient - 440°C	100 - 440°C
Temperature setting repeatability	1°C	1°C	1°C	1°C
Temperature readout	Digital	Digital	Digital	Digital
Heater indication	LED	LED	LED	LED
Heater warning	Text in display	Text in display	Text in display	Text in display
Over temperature protection	Yes	Yes	Yes	Yes
Temperature stability at 100°C	± 2°C	± 5°C	± 2°C	± 5°C
Temperature stability at 400°C	± 1°C	± 2°C	± 1°C	± 2°C
Heating time 20 to 400°C at 230 V	~35 min	~35 min	~40 min	~40 min
Time setting per step	1 - 999 min	1 - 1199 min	1 - 999 min	1 - 1199 min
Ramp control (Rate of heating)	Yes	No	Yes	No
Digestion applications memory	Up to 254	No	Up to 254	No
Digestion steps per application	Up to 23	1, Manual control	Up to 23	1, Manual control
Lift connection	Yes, full control	No	Yes, full control	No
Scrubber	Yes, full control	Yes, man control	Yes, full control	Yes, man control
Tubes / batch	8	8	20	20
Typical sample capacity				
Tube size	250 ml	250 ml	250 ml	250 ml
Sample size* solids	up to 5 g	up to 5 g	up to 5 g	up to 5 g
Sample size* liquids	up to 15 ml	up to 15 ml	up to 15 ml	up to 15 ml
Tube size	100 ml	100 ml	100 ml	100 ml
Sample size* solids	up to 1 g	up to 1 g	up to 1 g	up to 1 g
Sample size* liquids	up to 3 ml	up to 3 ml	up to 3 ml	up to 3 ml

*Note: Larger samples require special procedures. Please see the relevant Application Notes or consult our Customer Service Laboratory.

FOSS

FOSS Analytical
69, Slangerupgade
DK-3400 Hilleroed
Denmark

Tel.: +45 7010 3370
Fax: +45 7010 3371

info@foss.dk
www.foss.dk

